

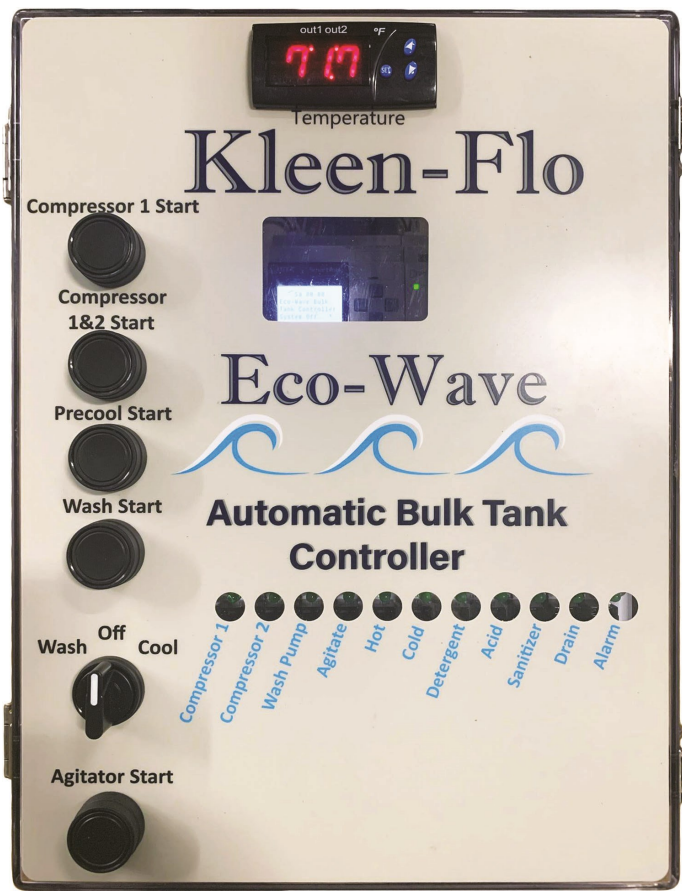

Eco-Wave Automatic Bulk Tank Controller



Installation & Operation Manual



Table of Contents

General Information.....	3
Cooling Features.....	3
Wash Features.....	3
Installation.....	4
Change Output Voltage.....	4
Programming the Smart Relay.....	5
List of Parameters in General Settings.....	6
First Rinse Cycle Parameters.....	7
Second Rinse Cycle Parameters.....	7
Detergent Cycle Parameters.....	7
Third Rinse Cycle Parameters.....	8
Acid Cycle Parameters.....	8
Sanitize Cycle Parameters.....	9
Manual Override Switches.....	9
Setting Date and Time.....	10
Accessing “PROGRAM” Mode in Temp Control Unit.....	10
Programming the Temp Control Unit.....	11
Parameters and Preprogrammed Settings For Temp Control Unit...	12
Operating Instructions.....	13
Inside the Enclosure.....	13
List of All Cycle Parameters and Preprogrammed Settings.....	14-15
To change Drain Valve from NO to NC.....	16
Drain Configurations.....	16
Technical Support.....	16
Wiring Diagram for Inputs/Outputs.....	17
Spare Parts.....	17
Troubleshooting.....	18
Inside Enclosure Wiring Diagram.....	19
Notes.....	19



Kleen-Flo Eco-Wave Bulk Tank Controller

General Information

The Eco-Wave Bulk Tank Controller is designed to cool and wash with a wide range of adjustable settings. For example: the length of cycles, etc.

Cooling Features

- ◆ Cooling cycles are adjustable
- ◆ Pre-cool option
- ◆ Agitator cycles are adjustable
- ◆ High temperature alarm
- ◆ Switches for manual override

Wash Features

- ◆ Up to 6 cycles can be programmed
- ◆ Unit can control all different types of drain systems (water pressure, electric, etc.)
- ◆ Up to 3 rinse cycles
- ◆ Wash cycles are adjustable
- ◆ Two options for sanitizing - at end of cycle or delay until preferred time of day
- ◆ Unit has an output to control an engine for powering a line shaft. This output is a dry contact
- ◆ All other output signals are 120/240Vac depending on input voltage
- ◆ Interface from 120/240Vac to 24Vac is available
- ◆ All outputs except engine output can be tested with built in test buttons. Note: no LED with test buttons - see note on pg 13
- ◆ Screen shows cycle and time remaining in cycle
- ◆ Option to manually advance through program for ease of service
- ◆ LED lights indicate which outputs are active
- ◆ Removable terminal plugs for ease of installation



Installation

Install Controller in desired location and supply 120/240Vac to unit.

For 24VAC out and 2 contactor interface, install part #40035

For 240VAC contactor interface box, install part #40040

Note: By default, Output power = input power. See instructions below for different output voltage.

Important: Always follow all local electrical codes

Engine run signal is a “dry contact” signal.

Vacuum pump signal can be delayed to allow engine to get to full speed before load is applied by using “AdvEngStart” parameter

When all installation/wiring is done and tested for functionality, unit is ready to power up and start programming.

Note: If unit is powered up without temp sensor installed, an alarm will sound and display will show 000.

To silence audible alarm push Set and Down arrow simultaneously on temp control.

Changing the output voltage

By default, input voltage equals output voltage. If different output voltage is desired, remove wire jumpers going from “X5” to “X6,Output feed” terminal (see picture below) and apply desired voltage into X6.

Note; The 5 amp fuse is for voltage feeding X6. Extra fuses are included.
(Inside bag beside the circuit board.)

Max Output Current

All Outputs Combined: 3A at 240VAC

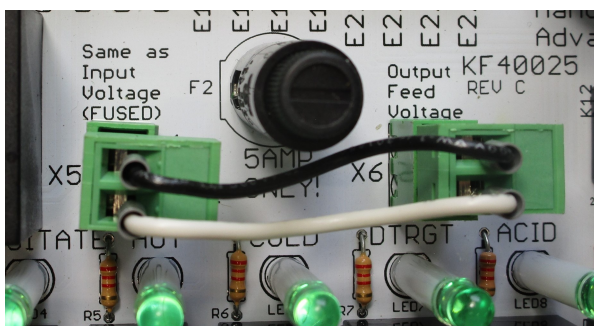

Programming the Smart Relay

With selector switch in “off “ position the screen should look like this:

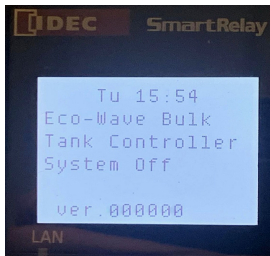

Press DOWN arrow then ESC. “Program” should be highlighted. If not, use up and down arrows keys to highlight “program”.

Press RIGHT arrow. “Set parameter” will be highlighted. Press OK.

“Cmp1StartDel” will be highlighted.

Press RIGHT arrow then press OK. Cursor will flash. Use the right and left arrow keys to move the cursor sideways and the up and down arrows to change the value 0-9, to set the desired time. Press OK then ESC to save setting and go back to parameter screen.

Press DOWN arrow to get to the next parameter to set.

“Cmp2StartDel” will be highlighted.

Press RIGHT arrow then press OK. Cursor will flash. Use the right and left arrow keys to move the cursor sideways and the up and down arrows to change the value 0-9, to set the desired time. Press OK then ESC to save setting and go back to parameter screen.

Press DOWN arrow to get to next parameter to set.

Repeat steps above for remainder of parameters.

Note: Move the cursor all the way to the right to change the time value from s (seconds), m (minutes) & h (hours).

Important: When setting the Chemical Pump timers, make sure the time value is set to seconds or minutes, NOT hours. Chemical pumps have an adjustable max run time.

List of Parameters in General Settings

Cmp1StartDel = Compressor 1 delayed start (min/sec)

Cmp2StartDel = Compressor 2 delayed start (min/sec)

Note: The two parameters above are only used to set delayed start when bulk tank is empty.

Cmp2RunDel = Compressor 2 run delay (min/sec)

Note: Used to set time between activation of compressor 1 and 2, when temp control unit calls for cooling.

PreCoolTime = How long selected compressors will run in precool mode (min/sec)

MaxPCoolTime = Safety feature which allows user to set maximum length of time for precool (min/sec) **Note: preset for 30 min**

PCoolCmp2Del = Adjustable time for compressor 2 to start after compressor 1 has started in precool mode (min/sec)

ManualAgiTmr = Adjustable time for agitator run time, when agitator start is activated (min/sec) (to agitate milk tank before pickup by milk hauler)

AutAgiOnTmr = "On" time for agitator after cooling is finished (min/sec)

AutAgiOffTmr = "Off" time for agitator after cooling is finished (min/sec)

TempAlarmDel = Time from when cooling starts until high temp alarm gets activated (min/sec) Used for first milking after wash. **Note:** See pg 10, parameter SP2 for more information.

ChemOvrFAlrm = Safety feature which allows user to set a maximum run time for chemical pumps (min/sec) **Note: preset for 10 min**

AdvEngStart = Adjustable time from when engine starts to when compressors start up

PowderDet = For use with Powdered Detergents so all hot water will be routed through detergent jar. **Note:** When set to "On", Hot water valve **must** be set for 30 seconds.

WashDelay = To set delayed start of wash. To bypass, press and hold wash start button for 2 seconds

First Rinse Cycle Parameters

Rin1HotTmr = Length of hot water fill time (min/sec)

Rin1ColdTmr = Length of cold water fill time (min/sec)

Rin1WashPump = Run time for wash pump (min/sec)

Rin1AddHot = Length of time for adding hot water after initial fill (min/sec)

Rin1AddCold = Length of time for adding cold water after initial fill (min/sec)

Rin1DrainOn = Run time for electric activated drain (if used) (min/sec)

Rin1EndCyc = Wait time before next cycle starts (min/sec)

Second Rinse Cycle Parameters

(Optional)

Rin2HotTmr = Length of hot water fill time (min/sec)

Rin2ColdTmr = Length of cold water fill time (min/sec)

Rin2WashPump = Run time for wash pump (min/sec)

Rin2AddHot = Length of time for adding hot water after initial fill (min/sec)

Rin2AddCold = Length of time for adding cold water after initial fill (min/sec)

Rin2DrainOn = Run time for electric activated drain (if used) (min/sec)

Rin2EndCyc = Wait time before next cycle starts (min/sec)

Detergent Cycle Parameters

DetHotTmr = Length of hot water fill time (min/sec)

DetChemPump = Run time for chemical pump (min/sec)

DetSanPump = Run time for sanitize pump (min/sec)

DetWashPump = Run time for wash pump (min/sec)

DetAddHot = Length of time for adding hot water after initial fill (min/sec)

DetDrainOn = Run time for electric activated drain (if used) (min/sec)

DetEndCyc = Wait time before next cycle starts (min/sec)

Third Rinse Cycle Parameters

(Optional)

Rin3HotTmr = Length of hot water fill time (min/sec)

Rin3ColdTmr = Length of cold water fill time (min/sec)

Rin3WashPump = Run time for wash pump (min/sec)

Rin3AddHot = Length of time for adding hot water after initial fill (min/sec)

Rin3AddCold = Length of time for adding cold water after initial fill (min/sec)

Rin3DrainOn = Run time for electric activated drain (if used) (min/sec)

Rin3EndCyc = Wait time before next cycle starts (min/sec)

Acid Cycle Parameters

AcidHotTmr = Length of hot water fill time (min/sec)

AcidColdTmr = Length of cold water fill time (min/sec)

AcidChemPump = Run time for chemical pump (min/sec)

AcidWashPump = Run time for wash pump (min/sec)

AcidAddHot = Length of time for adding hot water after initial fill (min/sec)

AcidAddCold = Length of time for adding cold water after initial fill (min/sec)

AcidDrainOn = Run time for electric activated drain (if used) (min/sec)

AcidEndCyc = Wait time before next cycle starts (min/sec)

Sanitize Cycle Parameters

PrMlkSan = Pre-milk sanitize on or off

PrMlkSanTime = Set up day of week and time of day for pre-milk sanitize

If manual pre-sanitize is preferred:

(When “PrMlkSan” is set to “On” and there is no day or time set in “PrMlkSanTime” the controller will not sanitize until it is manually advanced. Press the “Wash Start” switch for 2 seconds to advance.) (Only applies after wash cycle is completed.)

SanHotTmr = Length of hot water fill time (min/sec)

SanColdTmr = Length of cold water fill time (min/sec)

SanChemPump = Run time for chemical pump (min/sec)

SanWashPump = Run time for wash pump (min/sec)

SanAddHot = Length of time for adding hot water after initial fill (min/sec)

SanAddCold = Length of time for adding cold water after initial fill (min/sec)

SanDrainOn = Run time for electric activated drain (if used) (min/sec)

SanEndCyc = Time before display shows wash completed (min/sec)

Emergency Manual Override

In case of equipment failure where tank needs to be cooled manually, use the override switches. (See picture below) One for Compressor 1, one for Compressor 2, and one for Agitate.

WARNING!! When switches are in Manual Override, automatic cooling is not utilized. Cooling is activated until switches are returned to automatic!



Setting Date & Time

To set the date and time, press “Setup” (Located below “Program”) then press “clock”. If “clock” is not showing press “Switch to Admin”, the password is IDEC. Then press “Set Clock” to set date and time.

Note: Smart relay can be set to either “Admin” or “OP” mode. When in “Admin” mode, date and time can be set. When in “OP” mode, date and time cannot be set.

Accessing “PROGRAM” Mode in Temp Control Unit

Press and hold the “Set” button for 8 seconds until the display reads “0”

If no “Unlock Code” is set, press “Set” again, display should read “SP1”

Press “Set” to read the current setting in SP1 (default is 36.0), press the up or down arrow key to modify. Press “Set” to save and return to “SP1”

Press the “Up Arrow” to move to “SP2” press “Set” to read the current setting in SP2 (default is 42.0), press the up or down arrow key to modify. Press “Set” to save and return to “SP2”

Use the up and down arrow to scroll through all parameters and use the previously listed method to change parameters if needed

Press the “Set” and “Down arrow” simultaneously to exit program mode.

Unit will exit program mode after one minute if no buttons are pushed

Programming the Temp Control Unit

There are 36 parameters in the temp control. (See pg 12) Only 5 of them will need to be set for the specific farm during installation.

SP1 Set this temperature for compressors to turn off.

R1 Calculate R1 value by subtracting SP1 value from the preferred compressor start temperature. (This is the thermostat differential)

Example: Compressor should start cooling at 39 degrees and stop cooling at 36 degrees.

Set SP1 to “36”

Set R1 to “3” (Start Cool – Stop Cool) $39-36 = 3$

SP2 Set this temperature for alarm signal to turn off.

R2 Calculate R2 value by subtracting SP2 value from the preferred alarm activation point. (This is the alarm differential)

Note: Make sure parameter R0 is set to “Ind” otherwise alarm will not activate.

Example: Alarm should activate at 45 degrees and deactivate at 42 degrees.

Set SP2 to “42”

Set R2 to “3” (Activate Temp - Deactivate Temp) $45-42 = 3$

There is an option to delay the Alarm activation when starting first milking after wash, High Temp Alarm can be delayed in general settings under “TempAlarmDel”. See pg 6.

P1 If necessary, this parameter can be used to calibrate temperature sensor (+/- 20 deg)

Note: If the Bulk Tank Controller alarms at any point for 45 consecutive minutes or more, controller will latch alarm state “ON” until the Wash/Off/Cool switch is cycled.

Parameters and Preprogrammed Settings For Temp Control

Parameter	Description	Setting	User Setting
SP1	Set Point 1	36.0	
SP2	Set Point 2	42.0	
R0	Dependency SP1-SP2	Ind	
R1	Differential for SP1	3.0	
R2	Differential for SP2	3.0	
R3	Band differential 1.0	1.0	
R4	Lower value for SP1	30.0	
R5	Lower value for SP2	40.0	
R6	Higher value for SP1	45.0	
R7	Higher value for SP2	65.0	
R8	Regulation or operating mode	On1	
A0	Alarm differential	.1	
A1	Maximum alarm probe 1	50.0	
A2	Maximum alarm probe 2	90.0	
A3	Minimum alarm probe 1	30.0	
A4	Minimum alarm probe 2	99.9	
A5	Alarm verification time	18.0	
A6	Alarm probe 1 selection	AH	
A7	Alarm probe 2 selection	Ano	
C0	Minimum relay stop time	0	
C1	Operation relay 1	dir	
C2	Operation relay 2	dir	
C3	Default operation relay 1	OPN	
C4	Default operation relay 2	OPN	
P0	Temperature scale selection	°F	
P1	Calibration of probe 1	0.0	
P2	Calibration of probe 2	0.0	
P3	Decimal point	Yes	
P4	Probe to be displayed	SD1	
P5	Number of probes	1	
H0	Reprogramming	0	
H1	Keyboard protection	No	
H2	Operation LED OUT1	dir	
H3	Operation LED OUT2	dir	
H4	Address for serial communication	0	
H5	Access code to parameters	0	
H6	Probe type	Ptc	

Operating Instructions

On the front cover, there is a selector switch for WASH/OFF/COOL and five push buttons to start different cycles.

Turn the selector switch to WASH, then push WASH START when ready to start the wash cycle.

Press and hold the WASH START button for 2 seconds to advance to next segment of cycle. Release. Repeat as necessary.

Turn selector switch to COOL when ready to start cooling, then using the different start buttons, select which cooling mode option to start.

Compressor 1 Start: Starts cooling with only compressor 1 activated. Delay start time is adjustable.

Compressor 1&2 Start: Starts cooling with both compressors. Delay start time and the delay time between compressors are adjustable.

Precool Start: Starts selected compressors regardless of temperature of milk in tank. Run time is adjustable.

In precool, a delay can be set between the start of compressor 1 and the start of compressor 2.

Note: If temperature of milk calls for cooling during precool run time, the preset run time is canceled and the thermostat controls cooling.

Agitator Start: Push to start agitator for preset length of time.
(Used by milk hauler at pick up)

Inside the Enclosure

On the I/O board, there is a red push button on the top right. Pushing this button will advance through the segments in each cycle.

Note: This feature is only active in wash mode.

Bottom row of red push buttons are for testing outputs.

Note: Green LED lights will NOT come on when pushed, use a multimeter to test voltage on outputs.

Engine run signal is a dry contact that can control an Engine Start. Engine will stay on through complete wash cycle. To avoid overloading engine on start up, "AdvEngStart" parameter can be programmed to delay wash pump "on" signal.

Controller has one field replaceable surge protector to protect against power surges. It is installed in the top left corner of the controller by the black (L1) and red (L2/N) terminal blocks. If blown, remove it for temporary bypass. A replacement surge protector is # 40009. One spare # 40009 is included.

On the upper left side of the board (next to the power supply), there is a 3amp glass fuse to protect the board. Extra fuses are included.

List of All Cycle Parameters and Preprogrammed Settings

Parameter	Preprogrammed Settings	User Settings	User Settings
Cmp1StartDel	30 min		
Cmp2StartDel	30 min		
Cmp2RunDel	1 min		
PreCoolTime	20 min		
MaxPCoolTime	30 min		
PCoolCmp2Del	1 min		
ManualAgiTmr	10 min		
AutAgiOnTmr	5 min		
AutAgiOffTmr	30 min		
TempAlarmDel	3 hr		
ChemOvrFAlrm	10 min		
AdvEngStrart	0		
PowderDet	Off		
WashDelay	0		
Rin1HotTmr	5 min		
Rin1ColdTmr	5 min		
Rin1WashPump	3 min		
Rin1AddHot	2 min		
Rin1AddCold	2 min		
Rin1DrainOn	2 min		
Rin1EndCyc	3 min		
Rin2HotTmr	5 min		
Rin2ColdTmr	5 min		
Rin2WashPump	3 min		
Rin2AddHot	2 min		
Rin2AddCold	2 min		
Rin2DrainOn	2 min		
Rin2EndCyc	2 min		
DetHotTmr	5 min		
DetChemPump	2 min		



Parameter	Preprogrammed Settings	User Settings	User Settings
DetSanPump	0		
DetWashPump	8 min		
DetAddHot	6 min		
DetDrainOn	6 min		
DetEndCyc	5 min		
Rin3HotTmr	3 min		
Rin3ColdTmr	3min		
Rin3WashPump	3 min		
Rin3AddHot	2 min		
Rin3AddCold	2 min		
Rin3DrainOn	2 min		
Rin3EndCyc	3 min		
AcidHotTmr	0		
AcidColdTmr	5 min		
AcidChemPump	2 min		
AcidWashPump	4 min		
AcidAddHot	0		
AcidAddCold	3 min		
AcidDrainOn	3 min		
AcidEndCyc	0		
PrMlkSan	Off		
PrMlkSanTime	None		
SanHotTmr	0		
SanColdTmr	0		
SanChemPump	0		
SanWashPump	0		
SanAddHot	0		
SanAddCold	0		
SanDrainOn	0		
SanEndCyc	0		



To change Drain Valve from NO to NC

Install wire into black terminals L1 (hot) and route to I8 for drain valve as shown in picture below (only applies to electric operated drains)

Note: Wire is not supplied

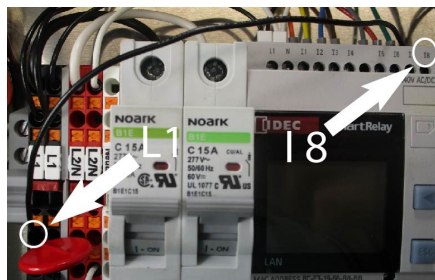

I8 for normally closed
drain valve

Drain Configurations

Water pressure drain (Mueller):

Set all add hot and/or cold timers to the length of time the drain needs to be closed after wash pump starts.

Electric Drains (Delaval, Surge etc.):

Set all “DrainOn” timers to the length of time the drain needs to be closed after wash pump starts.

Boumatic style drains:

Set all add hot and/or cold timers and “DrainOn” timers to 0.

Technical Support

Electronics 610.273.7016 Toll Free:888.768.3928

Gert:920.602.6724 (After hours)

EZee Main:717.768.7560 Toll Free:888.880.3933



Wiring Diagram for Eco-Wave Bulk Tank Controller Outputs/Inputs

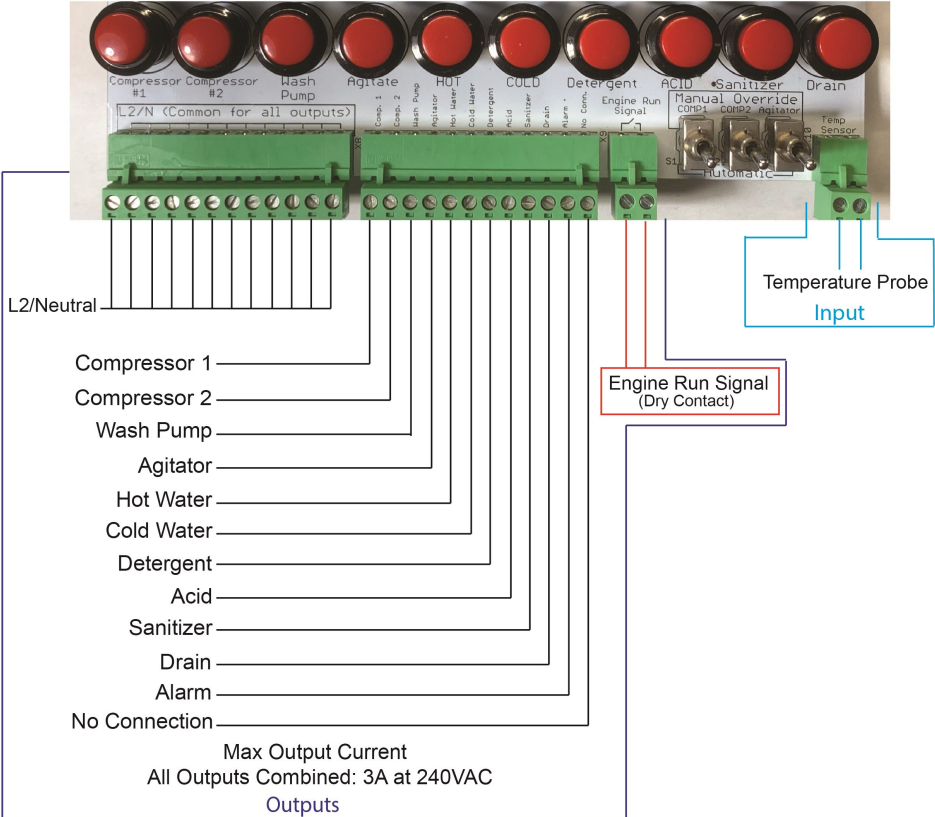

Recommended Spart Parts for Dealers to Have on Hand

Part#	Description	Part#	Description
10165	- Smart Relay	40026	- 3A Fuse 5x20mm
10168	- Expansion Module	40026-1	- 5A Fuse 5x20mm
40009	- MOV Surge Protector for 240VAC	40031	- Temperature Probe
40025	- Complete I/O Board	40036	- Temperature Control Unit



Troubleshooting

Alarm Message or Problem	1 Possible cause	2 Action
Indicators show activated, but no voltage on outputs, even with emergency override switches on Manual.	<ol style="list-style-type: none"> 1. Voltage lost at Output Feed Terminal (X6) (see page 4). 2. 5A Fuse is blown (see page 4). 	<ol style="list-style-type: none"> 1. Check voltage at X6 terminal, if voltage is present, check 5A fuse. 2. Replace 5A fuse if blown.
Chemical Pumps don't start filling when the water does	<ol style="list-style-type: none"> 1. Unit has built in timer that delays chemical. 2. Chemical Pump is not wired properly. 	<ol style="list-style-type: none"> 1. Wait 30 seconds after water starts 2. Inspect wiring
Circuit breaker/s are tripping	<ol style="list-style-type: none"> 1. Overvoltage protection Red MOV is bad. 2. Red MOV on circuit board is bad. 	<ol style="list-style-type: none"> 1. Remove and replace the MOV going from black terminals "L1 to red terminals "L2" 2. Replace the circuit board
Unit does not power up.	<ol style="list-style-type: none"> 1. 3A main power fuse is blown. 2. 3A and 5A fuses are blown. 3. Problem with main incoming power. 	<ol style="list-style-type: none"> 1. Replace 3A fuse. 2. Replace 3A and 5A Fuses. 3. Check incoming power and repair if no power is there.



Inside the enclosure wiring diagram

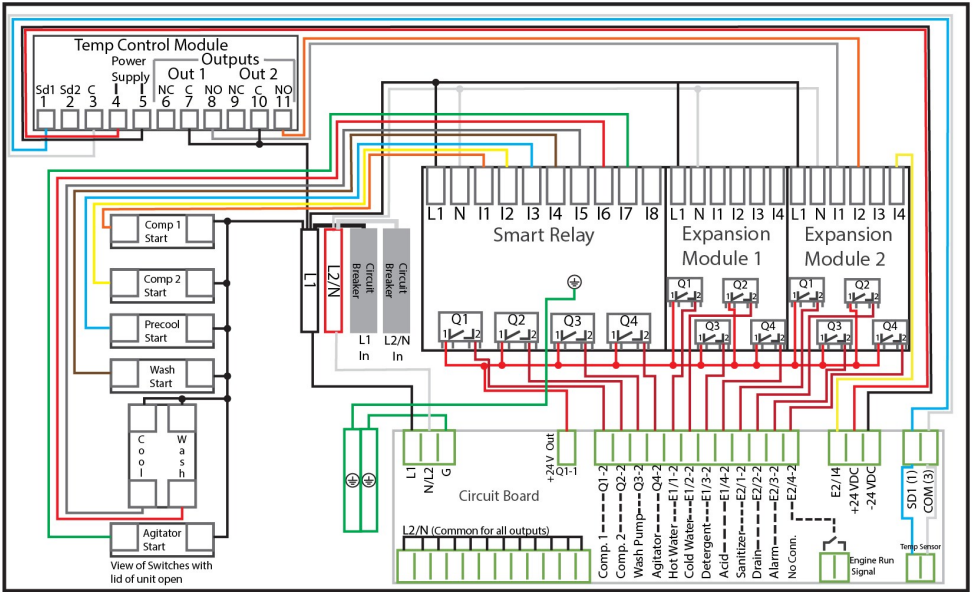

Notes



Eco-Wave
Automatic Bulk Tank Controller
Installation & Operation Manual

Rev 4.26

#40020

888.880.3933

www.ezmilking.com
